

EUROSTANDARD TRACK

ID CODE: 15

Esse-ci 3 circuit track is available in three versions. **EUROSTANDARD TRACK** can be selected for either non-dimmable spotlights or applications needing Bluetooth control. The **EUROSTANDARD PLUS TRACK DALI** has an extra 2 conductors for use in DALI applications and is also offered in a H-section version too, which can be used to add uplighting, if so desired. All versions come in different lengths and there are mounting options including direct, recessed, recessed trimless and suspended installation. All versions are available in a black and white powder coat, and some also offer plain silver anodized. A comprehensive range of installation accessories completes the offer.



Specifications

- The conductors are integrated in the track by means of rigid extruded profile made from insulating material guaranteeing high dielectric strength
- The 3 separate circuits consisting of 3 phase conductors and a common neutral allow for 3 lighting configurations to be switched individually. The 3-phase supply allows for an overall loading of 16 A (10500 VA) which can be divided among the 3 circuits (3x3500 VA)
- The earth positioned on the side leads to an asymmetrical structure of the track. As a consequence couplers must be selected carefully

Colour

- White RAL 9003 - Code: B
- Anodized - Code: C4 (not available for "H" version)
- Black RAL 9011 - Code: C8

Legal Ref. In compliance with the safety standards EN 60 598-1 and UNI EN 12464-1 (lighting for working places).

Certifications CE IP 20

Body Manufactured from die-cast aluminum.

COMPATIBLE PRODUCTS



QI
p. 296



SEMPlice LED
p. 76



TERES
p. 282



REM
p. 466



STYLO
p. 160



EUROSTANDARD TRACK

ON/OFF version.



IP 20

COD	
15AA1	1mt electrified track
15AA2	2mt electrified track
15AA3	3mt electrified track

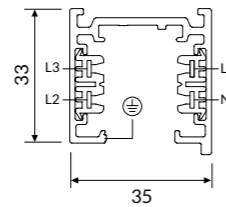

The cross section view shows the position of each line.

EUROSTANDARD PLUS TRACK DALI

Dimmable version.



IP 20

COD	
15AA1D	1mt electrified track
15AA2D	2mt electrified track
15AA3D	3mt electrified track
15AA4D	4mt electrified track

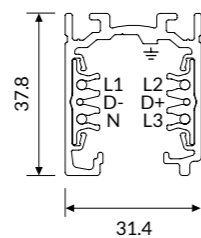

The cross section view shows the position of each line.

EUROSTANDARD PLUS TRACK DALI RECESSED

Dimmable version for recessed installation.



IP 20

COD	
15AA1DI	1mt electrified track
15AA2DI	2mt electrified track
15AA3DI	3mt electrified track
15AA4DI	4mt electrified track

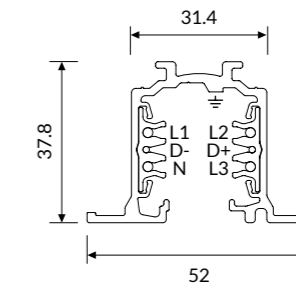

The cross section view shows the position of each line.

EUROSTANDARD PLUS TRACK DALI H

Dimmable version.

Possibility of using the upper part as a cable passage, or as housing for indirect luminaires or emergency groups.



IP 20

COD	
15AA1DH	1mt electrified track
15AA2DH	2mt electrified track
15AA3DH	3mt electrified track
15AA4DH	4mt electrified track

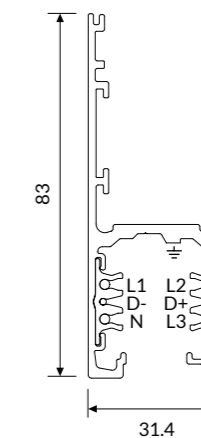

The cross section view shows the position of each line.

Accessories

ACCESSORIES FOR ON/OFF VERSION



15AA1330
Steel cable suspension kit.
Cable length 3000mm.



15AA09
End cap.



15AA09ELDX
15AA09ELSX
Live end 250V-50Hz max 16A.



15AA05DX
15AA05SX
L coupler ON-OFF 250V-50Hz
max 16A.



15AA06DX
15AA06SX
T coupler ON-OFF 250V-50Hz
max 16A.



15AA07
X coupler ON-OFF 250V-50Hz max 16A.



15AA12
Flexible coupler ON-OFF 250V-50Hz max
16A.



15AA11
Concealed straight coupler
ON-OFF 250V-50Hz max 16A.

ACCESSORIES FOR DALI VERSIONS



15AA165P
15AA167P
5 pole / 7 pole-ceiling rose power cable.
Cable length 2000mm.



15AA13D
15AA13DH: for H version
Steel cable suspension kit.
Cable length 1500mm.



15AA1330DH: for H version
Steel cable suspension kit.
Cable length 3000mm.



15AA14D
Ceiling mounting.



15AA17D
Bracket for recessed installation.



15AAGP1D
Additional IP40 cover strip.
Length 1000mm.



15AA09D
End cap.



15AA09DI
End cap for recessed version.



15AA09DH
End cap for H version.



15AA09ELDXD
15AA09ELSXD
Live end 250V-50Hz max 16A.



15AA09ELDXDI
15AA09ELSXDI
Live end 250V-50Hz max 16A
for recessed version.



15AA09ELDXDH
15AA09ELSXDH
Live end 250V-50Hz max 16A
for H version.

ACCESSORIES FOR DALI VERSIONS



15AA05DXD
15AA05SXD
L coupler 250V-50Hz max 16A for DALI version.



15AA05DXDI
15AA05SXDI
L coupler for recessed version.



15AA05DXDH
15AA05SXDH
L coupler 250V-50Hz max 16A for H version.



15AA06DXD
15AA06SXD
15AA08DXD
15AA08SXD
T coupler (internal 08/external 06) 250V-50Hz max 16A for DALI version.



15AA06DXDI
15AA06SXDI
15AA08DXDI
15AA08SXDI
T coupler (internal 08/external 06) for recessed version.



15AA06DXDH
15AA06SXDH
15AA08DXDH
15AA08SXDH
T coupler 250V-50Hz max 16A for H version.



15AA07D
X coupler 250V-50Hz max 16A for DALI version.



15AA07DI
X coupler for recessed version.



15AA07DH
X coupler 250V-50Hz max 16A for H version.



15AA11D
Concealed straight coupler 250V-50Hz max 16A.



15AA12D
Flexible coupler 250V-50Hz max 16A.



15AATC
Cutting tool for track conductors.

Technical Note

WEIGHT AND ELECTRICAL DIAGRAMS

Weight

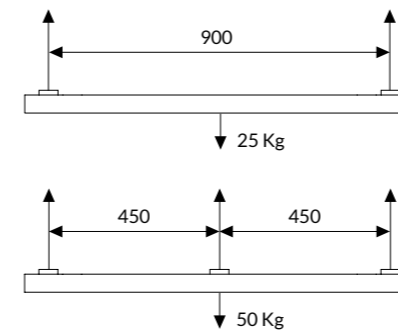

Electrical diagrams

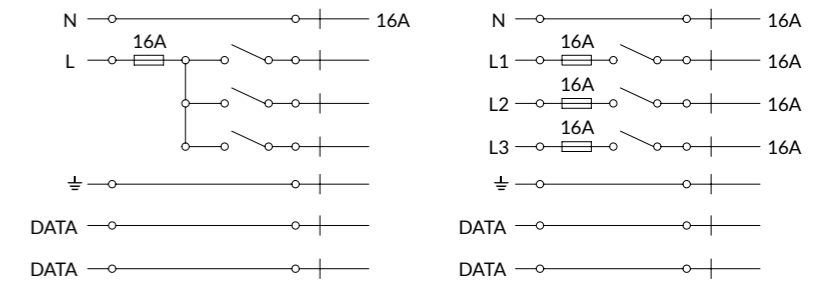

EXAMPLE OF INSTALLATION DIAGRAM WITH ITEM CODES

